

Gas Meter Specifications		
Product name	N4	
Maximum flow rate	4m ³ /h	
Starting flow rate	1L/h	
Chamber volume	0.9L/rev.	
Maximum operating pressure	3.5kPa	
Maximum pressure	10kPa	
Maximum index	9,999m ³	
Dimension	Height	232mm
	Width	174mm
	Depth	138mm
	Span (inlet and outlet)	130mm
Connection threads	W36.3 – 11.5	
Connection pipe	3/4B (20A)	
Weight	2.6kg	

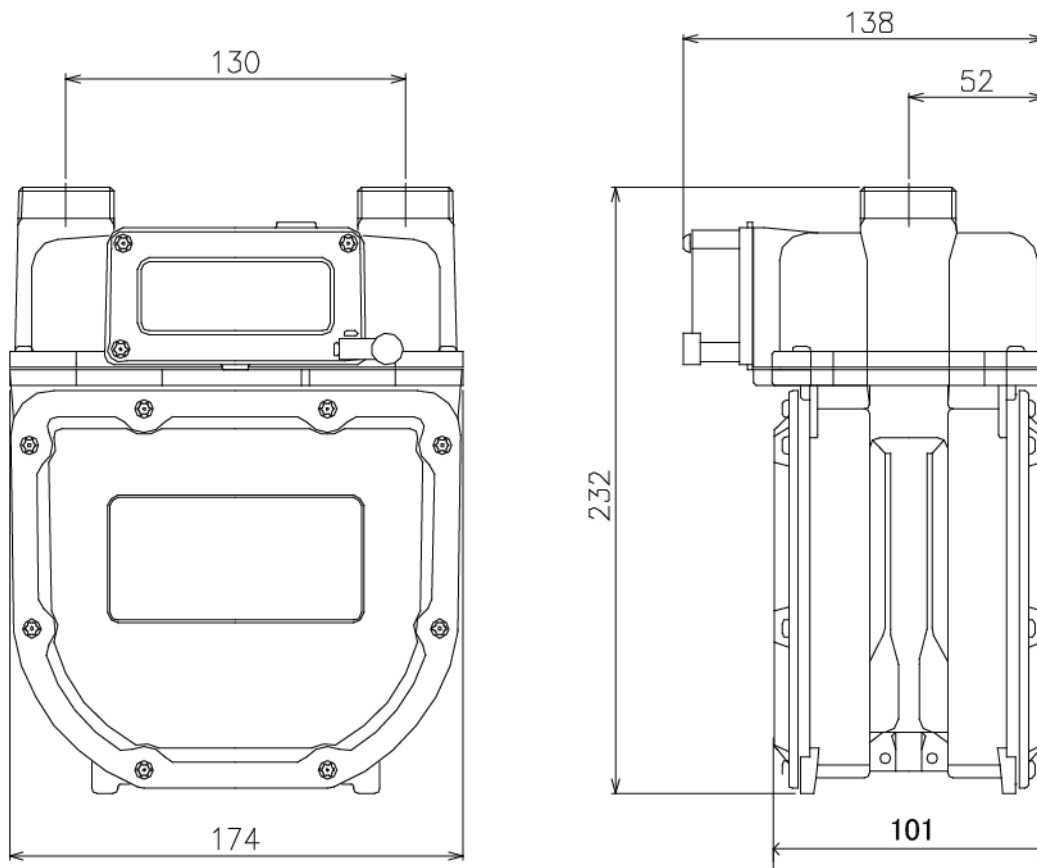

[Unit mm]

Gas Meter Specifications		
Product name	N6	
Maximum flow rate	6m ³ /h	
Starting flow rate	1L/h	
Chamber volume	1.7L/rev.	
Maximum operating pressure	3.5kPa	
Maximum pressure	10kPa	
Maximum index	9,999m ³	
Dimension	Height	262mm
	Width	195mm
	Depth	156mm
	Span (inlet and outlet)	130mm
Connection threads	W36.3 – 11.5	
Connection pipe	3/4B (20A)	
Weight	3.6 kg	

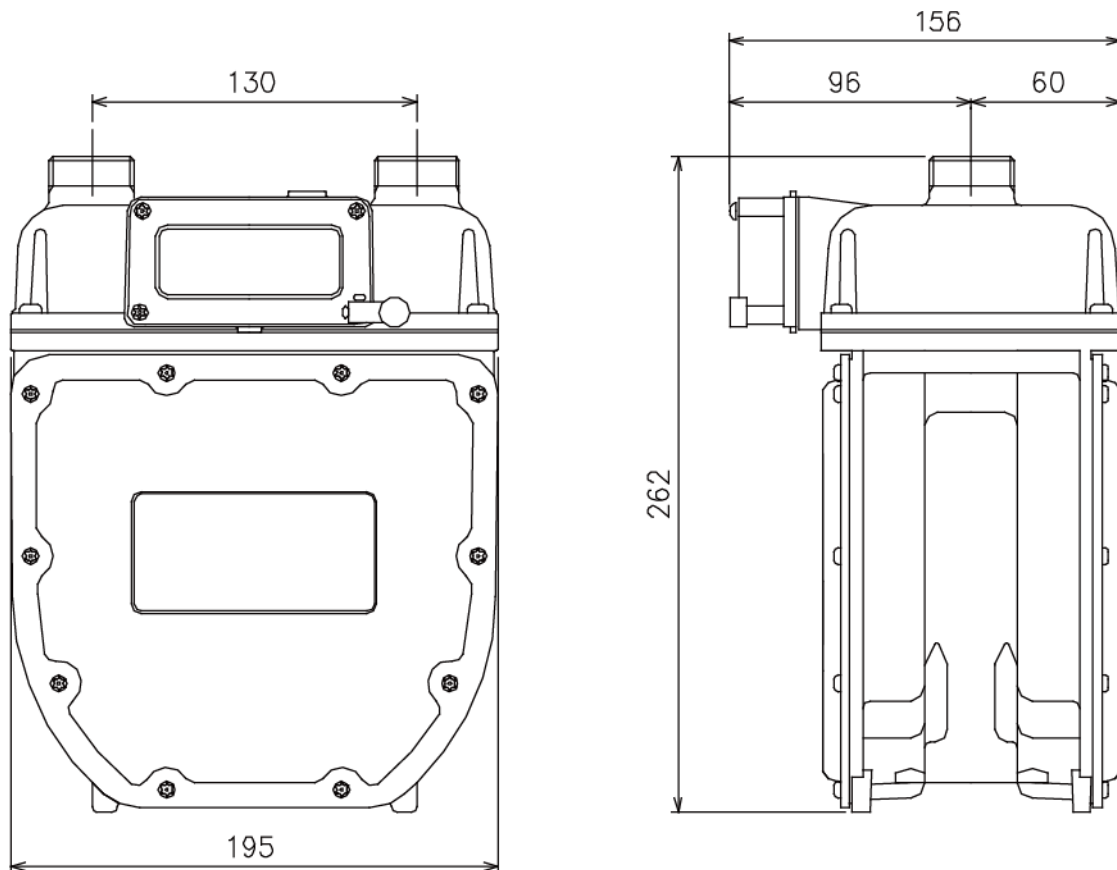

[Unit mm]